



**International Instruments**

# **MODEL 100C/MR05**

## **1" Round**



- Rugged, yet highly sensitive.
- Specifically engineered for commercial, industrial, military and OEM applications.
- Ideal for a wide range of instrumentation and control applications.

These precision meters combine small size, lightweight and high sensitivity with a rugged construction that withstand the extremes of shock, altitude, vibration and environment. They are self-contained, individually calibrated and are delivered ready for immediate installation.

- Black and White or Multicolored scales
- Black lance type pointers
- Zero positions available: left, center, right.

### **Specifications**

Electrical Ranges: DCuA : 100 / 200 / 500

DCmA: 1 / 5 / 10 / 50 / 100 / 200 / 500 / 4 – 20

DCmV: 50 / 100

Accuracy: 2% of Full Scale for DC models / 3% of Full Scale for AC models

Response Time: 2 Seconds (Max)

Overshoot: 20% Typical

Dielectric Strength: 1500 VRMS 60 Hz/ 1 Minute

External Zero Adjustment: No

Weight: 2 Ounces

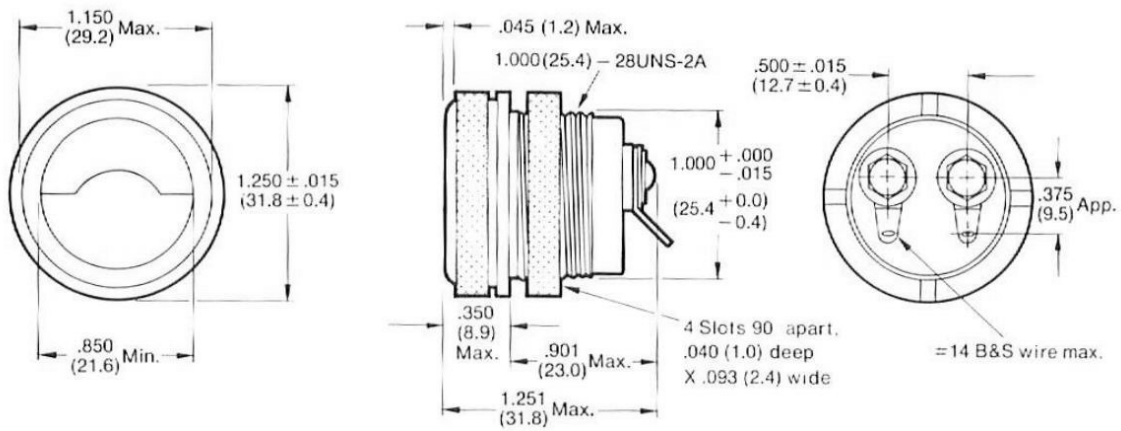

International Instruments was founded in 1947 with the purpose of developing reliable highly accurate analog panel meters. It has been a member of the Prime Technology group of companies since 1984. Give us a call to discuss your specific application requirements, or visit us on the web at [www.primetechnology.com](http://www.primetechnology.com)