



Prime Technology LLC  
Model 9295  
Time Domain Reflectometry  
Guided Wave Radar Tank Level System

**March 3, 2005**

Nick Graziano  
Prime Technology LLC



P.O. Box 185  
 Twin Lakes Road  
 North Branford, CT 06471

**I. OVERVIEW ..... 3**

**II. SYSTEM DESCRIPTION ..... 3**

    A. TANK LEVEL GUIDED WAVE RADAR SENSOR ASSEMBLY ..... 4

*Coax Cable*..... 4

*Guided Wave Radar Flange*..... 4

*Guided Wave Sensor*..... 4

    B. GUIDED WAVE RADAR ELECTRONIC CONVERTER ASSEMBLY ..... 4

*Housing*..... 5

*Electronics Module* ..... 5

*Electrical/Mechanical Interface* ..... 5

    C. TANK LEVEL SYSTEM ELECTRONICS ASSEMBLY..... 5

*9211 Chassis*..... 5

*Power Supply Module:*..... 6

*Prime Technology Model 9227 Smart Indicator Module:*..... 6

**III. QUALITY PROGRAM ..... 8**

    A. QUALIFICATION TESTING ..... 8

**IV. PROGRAM ..... 9**

    A. PROGRAM MANAGEMENT ..... 9

    B. PRELIMINARY DESIGN REVIEW ..... 9

    C. CRITICAL DESIGN REVIEW ..... 10

    D. SYSTEM INTEGRATION TESTING..... 10

    E. QUALIFICATION TESTING..... 10

    F. PRODUCTION RELEASE ..... 10

    E. PROGRAM SCHEDULE ..... 11

    F. PRICING ..... 11



P.O. Box 185  
Twin Lakes Road  
North Branford, CT 06471

## **I. Overview**

The Prime Technology TDR Tank Level System Model 9295 uses guided wave radar to measure tank levels. The system architecture is configured to allow for tank level measurements in a nuclear environment without the need to have nuclear hardened electronics.

This system meets the Navy Military specifications MIL-L-23886 and ASTM F2044, which are required for use with submarine applications. The tank level system is designed to keep all the active electronics outside of the nuclear containment area without significantly affecting the tank level system's accuracy.

The architecture is based on systems that Prime Technology presently has installed on the Virginia and SSGN class submarines. The difference between this system and the predecessor systems is the use of a guided wave radar sensor.

## **II. System Description**

The system configuration consists of three major assemblies. The three assemblies are:

1. The tank level guided wave radar sensor assembly
2. The guided wave radar electronic converter assembly
3. The Tank level system electronics assembly

The Preliminary System Specification for the system is shown in figure 1 and system Functional Block Diagram in figure 2.

The general operation of the system is described as follows. The Guided Wave Radar Electronic Converter Assembly sends a radar pulse thru the coax cable to the sensor probe in the tank. When the pulse encounters a change in impedance, which is caused by the material in the tank, part of the radar's signal is reflected back to the Guided Wave Radar Electronic Converter. The returning pulse is detected, the time of flight is calculated and the location of the media change is identified. The processed signal is encoded into a 4-20ma signal and sent to the Tank Level Electronics Assembly.

The Tank Level Electronics Assembly receives the signal from the Guided Wave Radar Electronics. The Prime Technology Model 9227 Smart Indicator Module processes the received 4-20ma signal. The Model 9227 checks the signal to make sure it is within its allowable range, curve corrects the signal based on tank geometry curves and converts the result into engineering units for display on the Model 9227's four digit display. A bargraph is also generated and displays the percent full of the tank. The Tank Level Electronics Assembly also has relay contact outputs that can be used to indicate low and high alarm points as well as an external alarm that can be silenced using an alarm

Prime Technology Sensitive

- 3 -



P.O. Box 185  
Twin Lakes Road  
North Branford, CT 06471

acknowledge toggle switch located on the Tank Level Electronics Assembly. By using guided wave radar, instead of through air type radar, the probability of false echoes is reduced.

### **A. Tank Level Guided Wave Radar Sensor Assembly**

The Tank Level Guided Wave Radar Sensor Assembly is the only assembly that is installed in the nuclear containment area. The assembly consists of a 100 foot hermetically sealed stainless steel sleeved silicon dioxide coax cable, a tank mounted guided wave radar flange and a guided wave radar sensor.

#### **Coax Cable**

The coax cable has unique characteristics, which reduce phase delays and errors associated with temperature. The coax cable incorporates two SMA type connectors on each end of the cable. The two connectors are used to interface with the guided wave radar sensor flange and the guided wave sensor electronics. The coax incorporates a stainless steel jacket and a silicon dioxide insulator. The cable is hermetically sealed to prevent wicking of any foreign materials into the cable.

#### **Guided Wave Radar Flange**

The guided wave radar flange is used to seal the tank, interface with the coax cable's SMA connector and the guided wave radar sensor. We will retain as much of the existing tank flange as possible if we cannot use the existing flange.

#### **Guided Wave Sensor**

The guided wave sensor utilizes a coax type design. This sensor uses a center conductor and an outer shield. The coax design uses insulated spacers to separate the two concentric conductors. The coax type design is used to reduce external dielectric influences that would hinder the sensing of material in the tank. This allows for the mounting of the sensor to existing structures. The sensor will have two bends to avoid the piping that presently exists in the Tank. The sensor will be constructed in three sections to allow for ease of installation into the tank.

### **B. Guided Wave Radar Electronic Converter Assembly**

The Guided Wave Radar Electronic Converter Assembly contains electronics that are used to generate the pulse for the sensor and also the electronics that are used to convert the pulse information reflected to a 4 to 20ma signal that is transmitted to the Tank Level System Electronics Assembly. This assembly is industrial grade equipment. Prime Technology is using a commercially available assembly, used in industrial applications,

Prime Technology Sensitive

- 4 -

Prime Products • General Resistance • International Instruments • Shurite Meters • Shurite Systems  
Telephone (203) 481-5721 • Facsimile (203) 481-8937 • Sales@primetechnology.com  
www.primetechnology.com



P.O. Box 185  
Twin Lakes Road  
North Branford, CT 06471

with key modification necessary to specifically support this application. The assembly will be mounted outside of the containment area.

This assembly consists of a housing, electronics module and the electrical/mechanical interface to the sensor.

### **Housing**

The housing for the guided wave radar electronics converter assembly consists of a cylindrical forged painted steel chassis with two screw-on end caps.

### **Electronics Module**

The electronics module consists of a plastic housing that contains PC board assemblies. The PC board assemblies are used to generate the pulse for the radar and the 4 to 20ma interface to the tank level system electronics assembly.

### **Electrical/Mechanical Interface**

The housing is bulkhead mounted outside of the containment area. The electrical connection to the guided wave sensor is made thru a SMA coax connector. This coax connector is connected to the coax that comes from the guided wave sensor.

## **C. Tank Level System Electronics Assembly**

The Tank level System Electronics Assembly consists of a Prime Technology Model 9211 Tank Level System that is designed to ASTM 2044F and MIL-L-23886. The design is modular to reduce the Mean Time To Repair (MTTR). The assembly is powered from 115 vac 60 Hz power (reference the 9211 functional block diagram figure 3).

The assembly consists of a chassis, Power Supply Module, Relay assembly, and Prime Technology's Model 9227 Tank Level Indicator.

### **9211 Chassis**

The chassis is similar, if not identical, to the chassis used in the Virginia and SSGN submarines (reference figure 4). The chassis contains the following:

- All the I/O connector interfaces to the Electronics Converter Assembly
- Electrical/mechanical sub-assembly interfaces for the Power Supply Module and the Model 9227 Indicator
- The Relay assembly, which is used to generate contact closures for Hi/Lo alarms.
- The I/O connection interfaces to the host system (the ship systems using the information gathered by the Tank Level System).

Prime Technology Sensitive

- 5 -



P.O. Box 185  
Twin Lakes Road  
North Branford, CT 06471

The Electronic Tank Level Assembly I/O connectors used on the chassis for the electrical interface are:

J1	MS3402D 14S-9P	Power Input Connector
J2	MS3402D 14S-7S	Not used
J3	MS3402D 14S-9S	Analog Retransmission
J4	MS3402D 20-11P	Lo and High Alarm relay interface
J5	MS3402 20-27SW	Transducer interface and system fault indication

The chassis is designed to allow for sub-assemblies to be quickly installed and removed from the front. The I/O connectors are located on the bottom of the chassis. The chassis is designed to be Bulkhead mounted using four mounting ears located at the top and bottom of the chassis.

### **Power Supply Module:**

The power supply module consists of an AC to DC power supply, fuse-condition indicating holder, AC power on indicator, power on/off switch, set switch, alarm acknowledge switch, test potentiometer, test switch, up/down switch and cloning port connector. The AC to DC power supply converts 115vac 60hz, switched, fused power into unregulated +28vdc that is used by the modules in the panel.

The test potentiometer, test switch, and channel select switch are used in conjunction with each other to apply a test signal to the channel selected. The Alarm Acknowledge switch is used to reset the local alarm lamp when an alarm is active. When the switch is moved into the alarm acknowledge position, and an alarm exists, the alarm indicator on the power supply module turns off. The set and UP/DN switches are used for setup of the alarm levels on the indicator modules as well as other selectable features. The cloning port (patented by Prime Technology) is used to clone the curve characteristics of the Smart Indicator located in the channel one position to the Smart Indicator to be attached to the cloning port.

### **Prime Technology Model 9227 Smart Indicator Module:**

The overview of the functionality of the Model 9227 is presented here. For a more in-depth description of its features refer to the 9227 Manual and Specification documents in appendix 1.

The mechanical configuration of this module is the same as that used on Virginia Class submarines with the Model 9227s predecessor; the Model 9212. The electrical interface is also similar (Reference figure 5 for the mechanical configuration of the Smart Indicator Module) to that used in the Virginia class application. The Model 9227 is used to process the analog signal based on a curve correction table.

Prime Technology Sensitive

- 6 -



P.O. Box 185  
Twin Lakes Road  
North Branford, CT 06471

The curve correction table is used to correct for geometry issues related to the physical shape of the tank being used. The 9227 selects a curve by either reading dip switches, which are located on the 9227's interface pc board in the chassis, or from curve selections made during the 9227's software programming setup menu.

The analog front end of the Model 9227 Smart Indicator receives a 4-20ma signal from the guided wave radar electronics assembly via the chassis connector J5. The signal is applied to the Smart Indicator using a 249-ohm load located in the 9227. The signal is then applied to an analog multiplexer. The multiplexer selects the input signal via commands from the microprocessor and applies it to an Instrumentation Amplifier. The Instrumentation Amplifier buffers and gain adjusts the signal, corrects offsets and applies it to the input of an A/D converter. The A/D converter converts the analog signal to a digital signal, and then serially transmits it to the microprocessor. The Microprocessor adds curve correction based on a curve selected from the processor memory. The microprocessor curve corrects the signal based on curve information that is stored in the Model 9227 Smart Indicator's memory. The curve corrected signal is compared to the high and low tank level settings and displays the tank volume both, in absolute terms on the four digit LED display and, in relative terms, on the percent of maximum tank volume on the bargraph. The high and low relay output control lines are set accordingly. An isolated analog retransmission signal (to the host system) is output to the chassis's J 3 connector if required.

The Smart Indicator's voltage regulator circuit develops three voltages; +12vdc, -12Vdc and +5vdc. A 2.5 volt reference is developed from the 5vdc source for use by the A/D.

A power monitoring circuit is used to turn the processor on only when power is within an appropriate range thereby protecting the processor.

The memory used on in the Smart Indicator consists of 3 serial modules consisting of 8 Kbytes of serial nonvolatile memory. This memory is used to store the tank curves that the Smart Indicator uses for tank data correction (linearization).

The Model 9227 contains a Built In Test (BIT) feature that continuously monitors the analog channel, the 9227's power supplies, and the microprocessor.

The Model 9227 uses the switches located on the Tank Level System's Electronic Assembly Power Supply Module for set-up and calibration. The 9227 has a

Prime Technology Sensitive

- 7 -



P.O. Box 185  
Twin Lakes Road  
North Branford, CT 06471

feature called “cloning” which allows the user to load new data curves into the 9227 or to read curves from the 9227. Updates to the code in the 9227 can also be changed by serially down loading thru the serial/cloning port on the power supply. This provides the capability to reprogram either the tank curve fit data or the operational code of the Model 9227 without affecting the hardware.

### **III. Quality Program**

Prime Technology adheres to a rigorous Quality Program that conforms to the Nuclear Power Issues Committee (NUPIC) 10CFR50 Appendix B and 10CFR21. We also conform to MIL-I-45208 for inspection and MIL-STD-45662A for calibration.

Prime has provided life critical products to a variety of military and non-military applications. We are one of few manufacturers that adhere to the NUPIC Quality standards. This same quality program provides exceptional confidence for our military customers requiring a thorough quality standard.

Parts selection is accomplished in concert with the end item specification requirement. Parts are selected in support of the reliability criteria of the product as well as the practical impact of cost and schedule adherence. We adhere to military specification criteria only if it adds substantial performance without technical risk, cost and schedule impacts. To ensure the reliability of the product we perform a one hundred hour burn in at 50 degrees centigrade prior to final test and acceptance. All parts are controlled in reference to the original qualification configuration.

Prime’s complete Quality Manual is available online at our website. The website address providing the availability to download the manual is:

<http://www.primetechnology.com/company1.cfm?hiLite=1>

### **A. Qualification Testing**

The specifications used on this development are MIL-L-23886 and ASTM F2044. The Tank Level Electronics Assembly has already gone through environmental testing. The Qualification testing will be limited to the Guided Wave Radar Electronics, Coax cable, Tank Flange and Sensor. The following Environmental tests are assumed to be required.

- a. DC Magnetic Field:  
Per Mil-STD-1399 section 070.
- b. Enclosure:  
MIL-STD-108E Drip Proof
- c. Temperature:
  1. Operating:

Prime Technology Sensitive

- 8 -



P.O. Box 185  
Twin Lakes Road  
North Branford, CT 06471

- 0-50 degrees C
- 2. Non-operating  
-20 to 80 degrees C
- d. Vibration:  
Per MIL-STD-167-1
- e. Shock:  
Per MIL-STD-901C
- f. Humidity:  
95 % non-condensing
- g. EMI  
Per MIL-STD-461D  
Methods: CE101/CE102/RE101/RE102/CS101/CS114  
CS116/RS101/RS103
- h. Radiation Test (Sensor and Coax only)

#### **IV. Program**

##### **A. Program Management**

Prime will assign a Program Manager to the project for responsibility of the financial, schedule and performance requirements dictated by the contract terms and conditions and the product Specification and Statement of Work. The Program Manager will be responsible for all aspects of the project including communications with the customer.

Weekly review meetings provide a concrete communication process in support of the program. Included in the program team will be members of design, manufacturing engineering, drafting, quality control and purchasing. Engineering logbooks are required for our Program Managers to ensure accurate historical representation of decisions and evaluations of various aspects of the program.

##### **B. Preliminary Design Review**

Upon award of the order, Prime Technology will commence the design process for the system and will prepare a Preliminary Design Review (PDR) approximately 4 weeks from the date of award. This PDR will cover, in detail, the various technical decisions made to satisfy the requirements imposed by the application specifications. This PDR will be presented to generate a dialog for satisfaction of the approach in meeting the requirements. After the PDR, Prime Technology will commence work on the “accepted” specifics of the design.

Prime Technology Sensitive

- 9 -



P.O. Box 185  
Twin Lakes Road  
North Branford, CT 06471

We anticipate the PDR to be held in North Branford at Prime Technology and to be a one-day event. The PDR documentation will be an informal package of Power Point Slides presented at the discussion.

### **C. Critical Design Review**

The Critical Design Review (CDR) will be performed prior to the acceptance of the final drawings representing the production configuration. The CDR will cover the actions from the PDR; the details of the final configuration and any risk issues associated with the final design criteria. Upon completion of the CDR, Prime will complete the manufacture of the initial system.

We anticipate the CDR to be held in North Branford at Prime Technology and to be a one-day event. The CDR documentation will be an informal package of Power Point Slides presented in an informal discussion format. The manufacturing drawing package will be available for review and discussion at the CDR.

### **D. System Integration Testing**

Prior to entering into full Qualification Testing, Prime will perform extensive System Integration Testing to verify the operation of the system to the system specification. This testing will be performed in Prime's engineering lab with the involvement of the design engineer, the Program Manager and Prime's Quality representative. Results of this testing will be documented and archived with the engineering development documentation relating to this system.

### **E. Qualification Testing**

The Qualification Testing will be performed at a third part laboratory under the direction of Prime Technology. The tests will be performed to the appropriate military specifications and requirements. An independent laboratory will create a formal test report. Prime will include this formal report within the qualification report submitted to Electric Boat in support of the program.

Prime typically uses Retlif Laboratories or Dayton T. Brown Laboratory in Long Island New York for our third part laboratory requirements.

Our customers, and DoD representatives if applicable, are invited to witness the testing.

### **F. Production Release**

Prime will perform a configuration review prior to the initial release of the documents for full production. This process is a check against the development process to ensure that all

Prime Technology Sensitive

- 10 -



P.O. Box 185  
 Twin Lakes Road  
 North Branford, CT 06471

corrective actions, change notices and other organic changes to the design are formally completed and the design is set as “static”. All further changes will be within the formal configuration management and control system the Prime provides as part of our military program controls. The details of this program are available in Prime’s Quality Manual.

**E. Program Schedule**

The following milestones represent the key schedule parameters for the overall program. A detailed Gantt chart is available for review to assess the detailed schedule.

Contract Award	
Preliminary Design Review	6 wks. From ARO
Critical Design Review	18 wks. From ARO
System Integration Testing	38 wks. From ARO
Qualification Testing Complete	54 wks. From ARO
Production Release (Qual Approval)	63 wks. From ARO
Initial System Available	71 wks. From ARO

**F. Pricing**

The following pricing are estimates. We advise to use these only as rough budgetary numbers. As we develop a specification and a statement of work that is understood and accepted by our customer, we will prepare an accurate price estimate for the establishment of a purchase order or contract.

Non-Recurring Tasks

- Preliminary Design Review
- Critical Design Review
- Design
- Documentation
- Prototype
- System Integration
- Qualification Documentation
- Qualification
- User’s Manual
- Test Procedures

Non Recurring Pricing

Budgetary Estimate

Recurring

Budgetary Estimate

Prime Technology Sensitive  
 - 11 -

## Figure 1 System Specification

- a. Power:  
115vac 60 Hz per Mil-STD-1399 section 300.
- b. DC Magnetic Field:  
Per Mil-STD-1399 section 070.
- c. Enclosure:  
MIL-STD-108E Drip Proof to 45 degrees.
- d. Tank Level Latency:  
500ms from Tank Level input to retransmission
- e. Accuracy:
  - 1. System:  
1.7% of Full Scale.  
+/- 1.0 inches over 60 inches
  - 2. Analog Retransmission:  
0.2% of displayed value
- f. Temperature:
  - 1. Operating:  
0-50 degrees C
  - 2. Non-operating  
-20 to 80 degrees C
- g. Vibration:  
Per MIL-STD-167-1
- h. Shock:  
Per MIL-STD-901C
- i. Humidity:  
95 % non-condensing
- j. EMI  
Per MIL-STD-461D  
Methods :  
CE101/CE102/RE101/RE102/CS101/  
CS114  
CS116/RS101/RS103
- k. Tank System Fail Alarm Controls.
  - 1. Double Pole Double throw 1 Amp 115vac Inductive
  - 2. All contacts doubled up

Prime Technology Sensitive

- 12 -

**Figure 2**  
**Guided Wave Radar Mechanical Drawing**

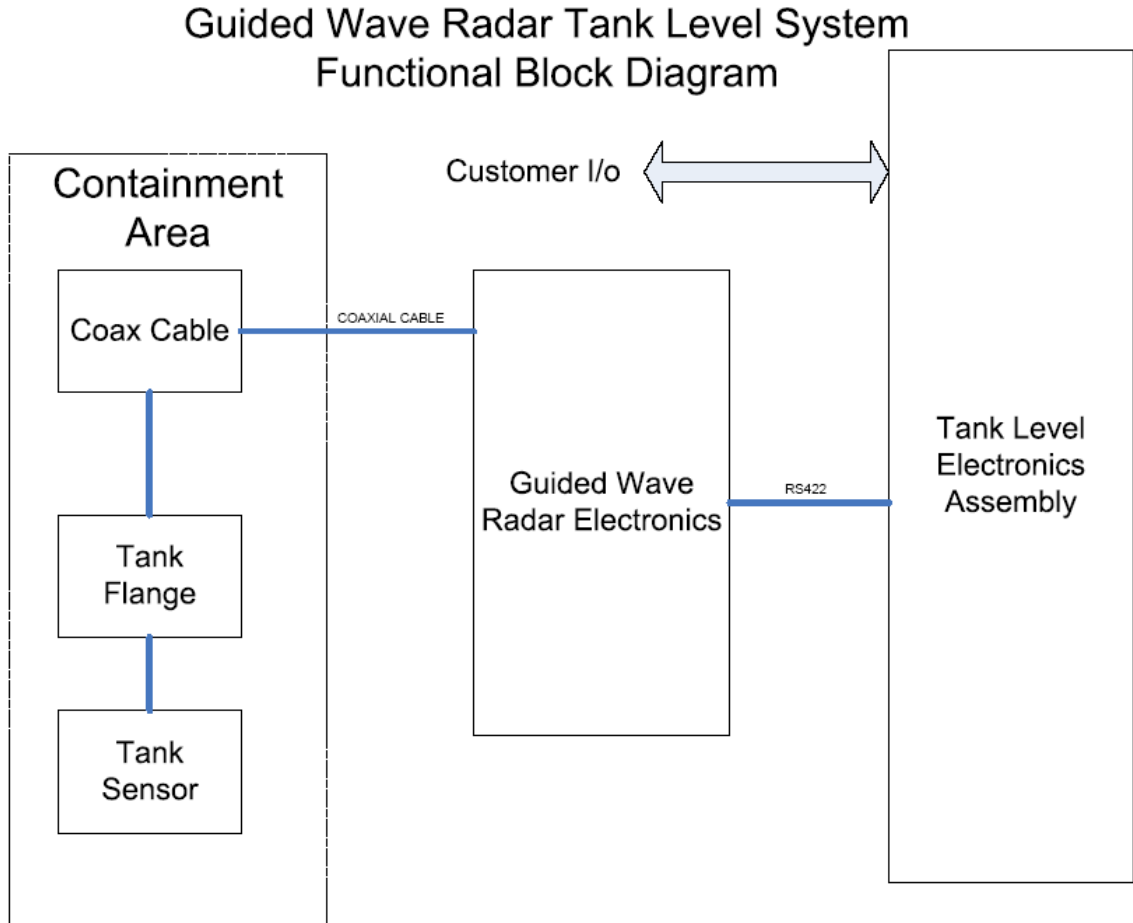

**Figure 3**  
**Model 9211 Functional Block Diagram**

**9211 Tank Level  
Electronics Assembly**

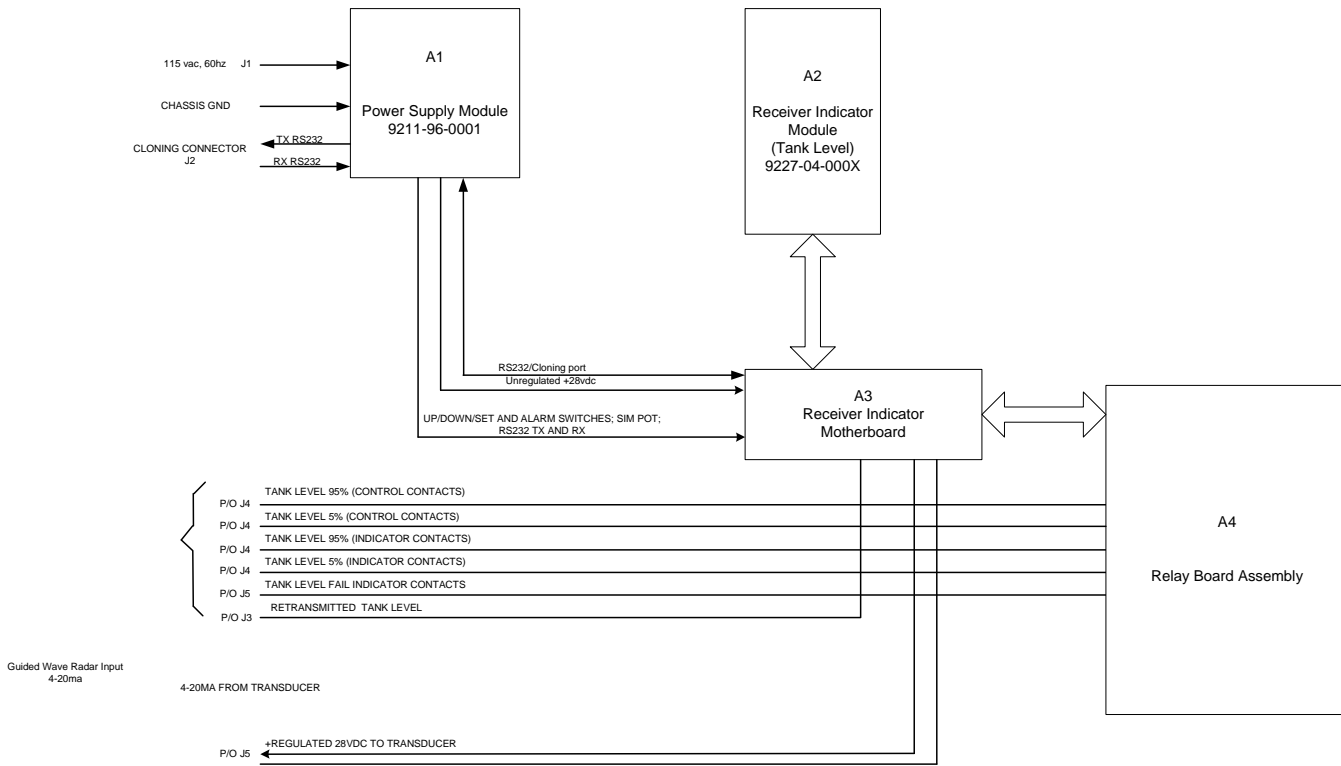

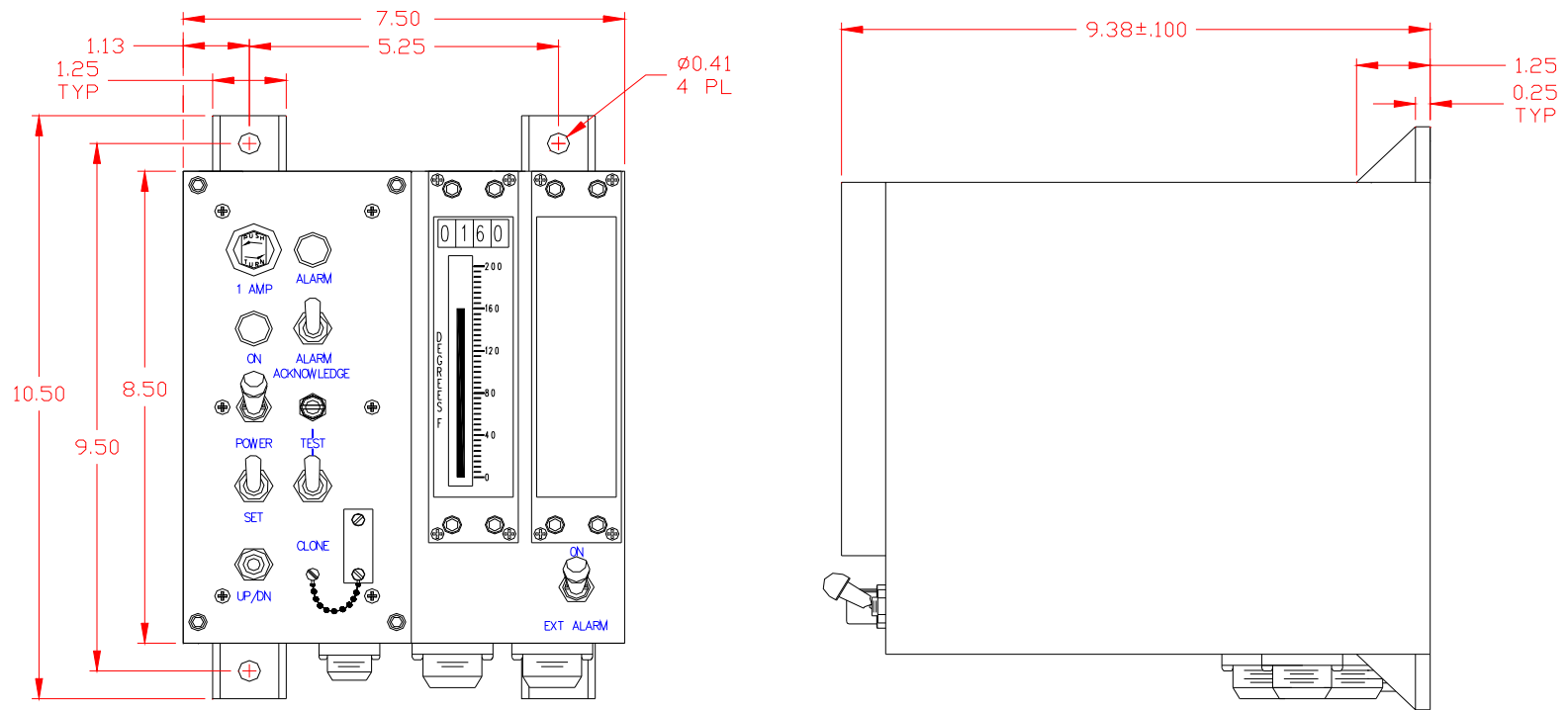

**Figure 4**  
**9211 Chassis**

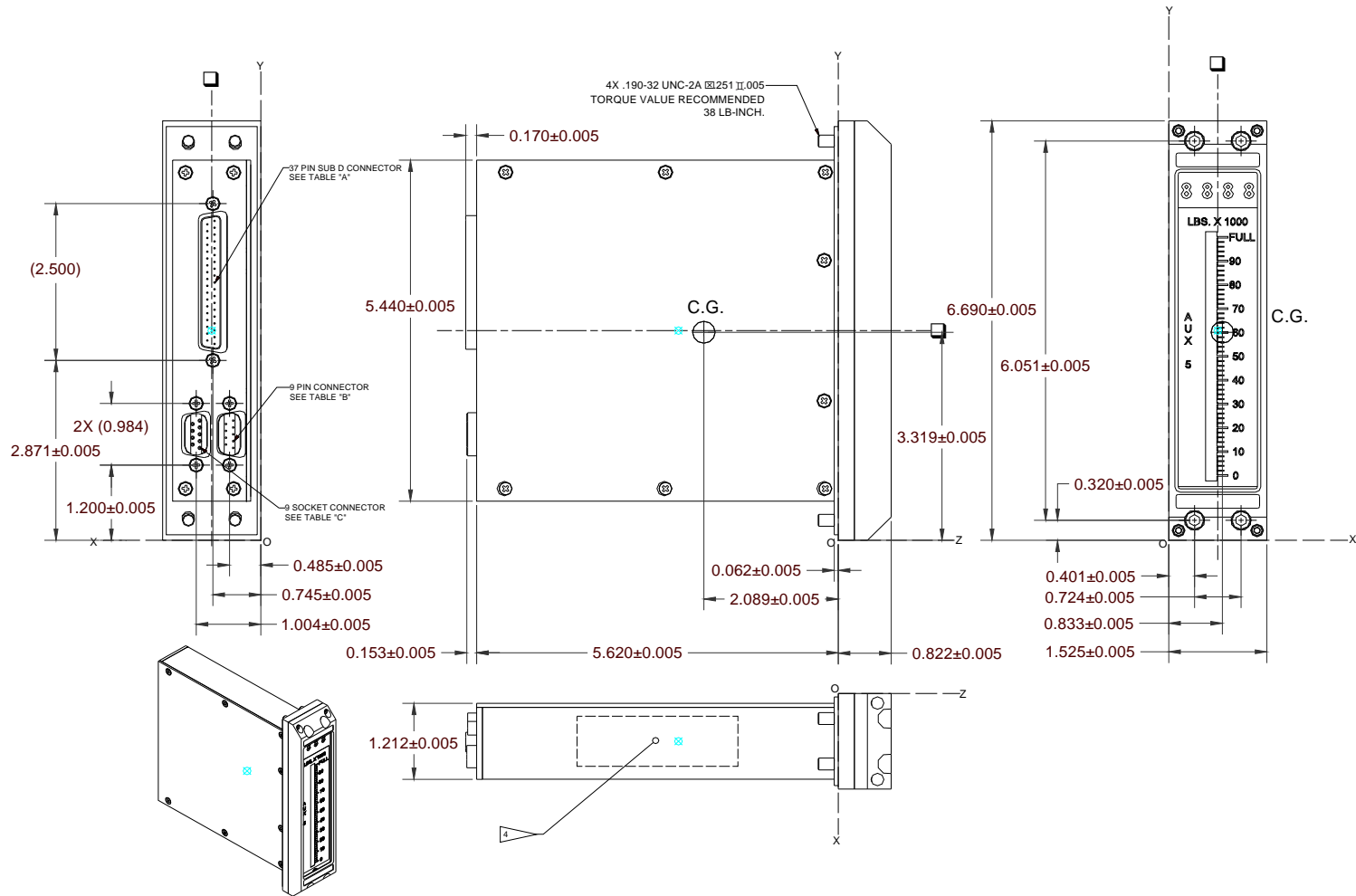

Prime Technology Sensitive

- 16 -

**Appendix 1**  
**Model 9227 Manual and Specification**